

**Quick Reference Guide to System**  
**OKIMAT RF 2,40GHz**  
**DELUXE N RF / CLASSIC N RF / SMARTLINE RF**

**1. System overview**

The system comprises a double drive of the **OKIMAT RF 2,40GHz** type with integrated 32-channel radio receiver enabling trouble-free operation of several drive systems within the radio system's transmission range.

**Front view:**

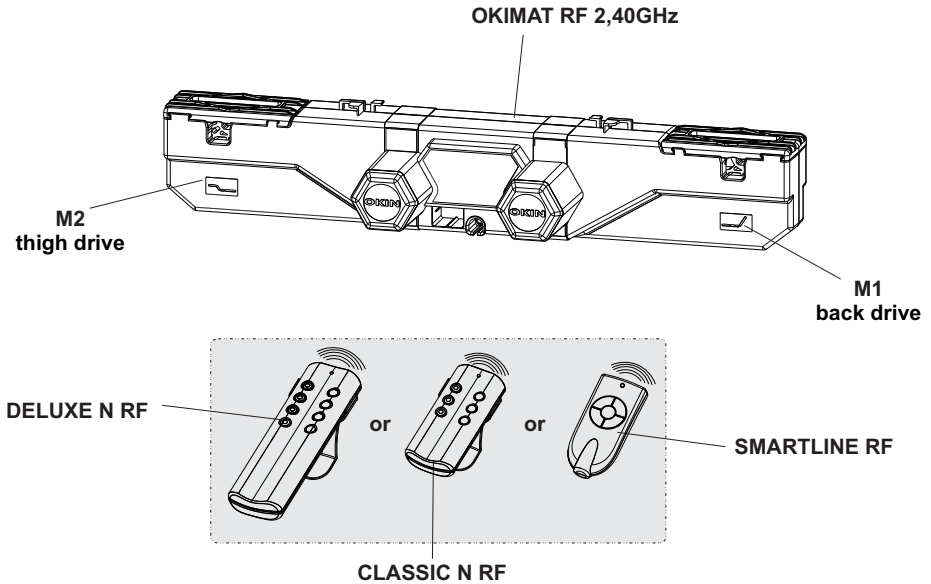

**Back view:**

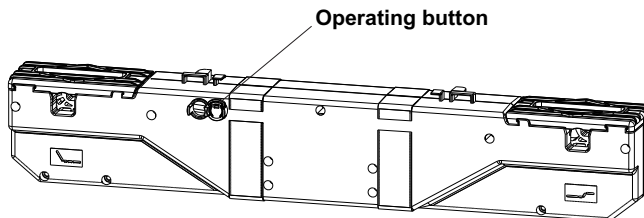

# Quick Reference Guide to System

OKIMAT RF 2,40GHz

DELUXE N RF / CLASSIC N RF / SMARTLINE RF

## 2. Inserting or changing batteries

### CLASSIC N RF and DELUXE N RF

- Insert a coin into the slot in the top of the transmitter. Turn the coin obliquely and carefully press the two halves of the housing apart.
- Change the battery. Only use batteries of the CR 2032 type.  
**Ensure correct polarity (+/-).**
- Press the two halves of the housing back together.

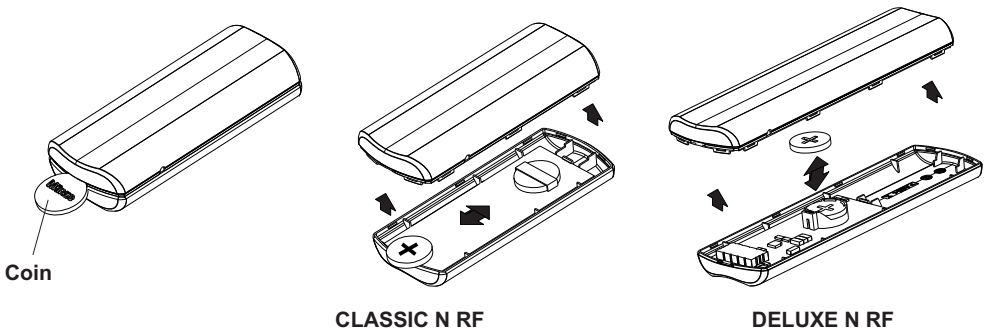

### SMARTLINE RF

- Remove the battery compartment cover.
- Insert the batteries (AAA) into the remote control.  
**Ensure correct polarity (+/-).**
- Replace the cover.

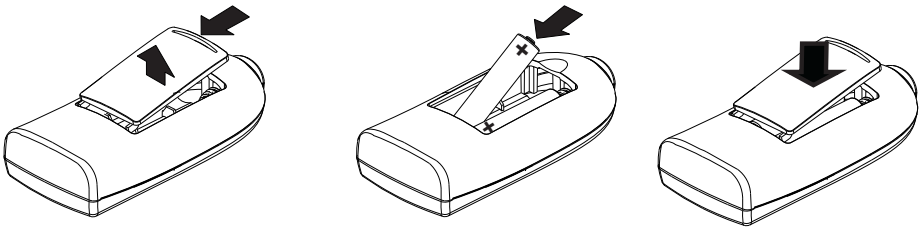

Do not dispose of batteries with the normal household waste!



### 3. Attaching or removing the fastening clip (DELUXE N RF and CLASSIC N RF)

- To attach, press the fastening clip (1) into the two notches (3) on the backside (2) of the transmitter. The fastening clip snaps into place.
- To remove, prize the fastening clip **carefully** out of the two notches (3).

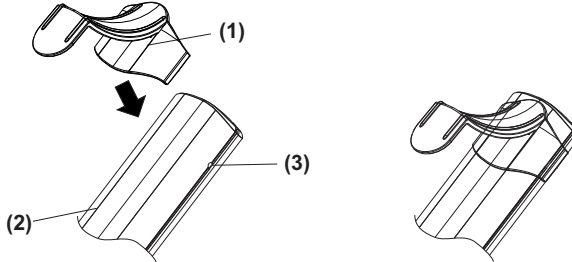



### 4. Button configuration and symbols

The transmitter **DELUXE N RF** is a radio transmitter with a maximum of 8 pushbuttons. The transmitter **CLASSIC N RF** is a radio transmitter with a maximum of 6 pushbuttons. The transmitter **SMARTLINE RF** is a radio transmitter with a maximum of 5 pushbuttons. The number and function of the buttons depends on the equipment and function of the drive system. For more information about the button functions please refer to the specifications of your handset to be replaced.

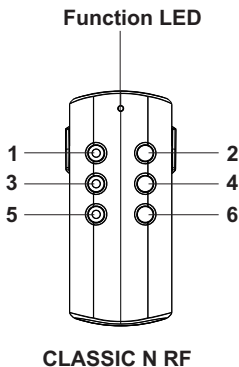
#### Hand transmitter examples:



Symbol	Function
	Back adjustment
	Thigh adjustment
	Adjustment of all drives simultaneously

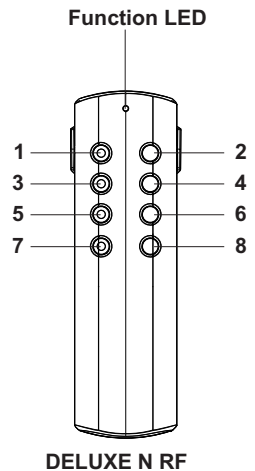

Key	Function
1,3,5	Drives up
2,4,6	Drives down
1+2 tog..	= Floor lighting

Key	Function
1,3,5	Drives up
2,4,6	Drives down
7,8	= Floor lighting

# Quick Reference Guide to System

OKIMAT RF 2,40GHz

DELUXE N RF / CLASSIC N RF / SMARTLINE RF

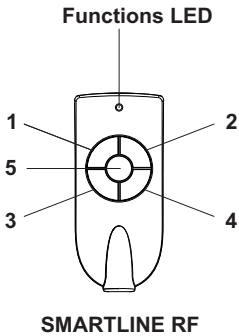

Button	Function
1,2	Drives UP
3,4	Drives DOWN
5	Drives Reset

## 5. Putting into operation

### 5.1. Operating button

- Connect the drive with voltage supply.
- Wait at least 10s before proceeding with the following steps.
- In order to carry out these steps, it will be necessary to actuate the **operating button**. By pressing the button, various drive functions can be called up.

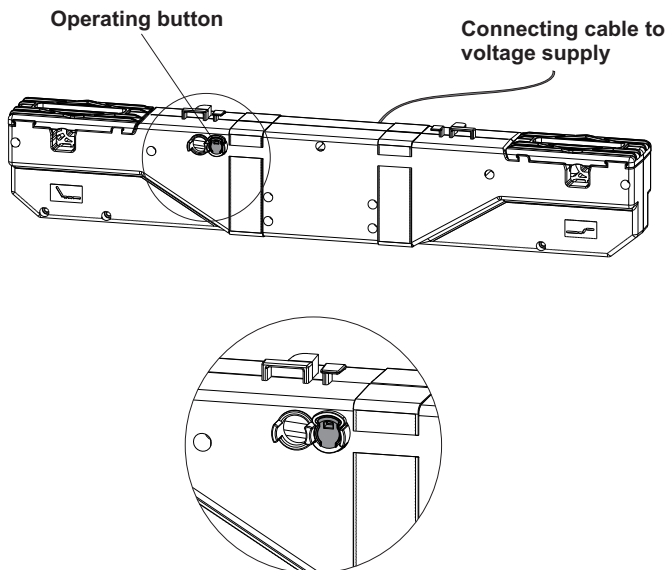

## 5.2. Programming the DELUXE N RF / CLASSIC N RF / SMARTLINE RF transmitter

In order to put the handset into operation, radio communications with the drive must first be established. To do this, proceed as follows:

- Give the **operating button** on the **drive 2x short press** (doubleclick) in succession. The **LED under the operating button** comes on after the second pressing, the **drive** now switches to the learning mode for approx. 10s.
- Press **buttons 1-2 simultaneously and keep them pressed** until the LED under the operating button extinguishes and the function LED glows constantly (programmable process approx. 10s). The learning mode of the transmitter is completed.
- The transmitter is ready for operation.

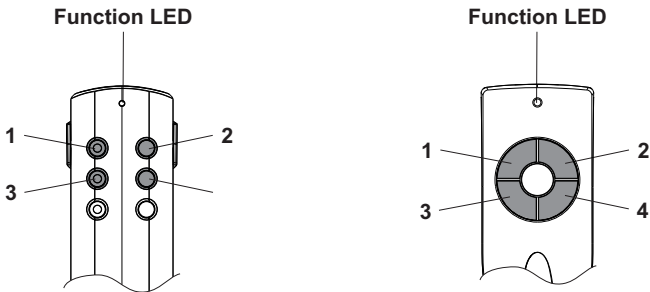

If the drive does not start up when the button is pressed, briefly release the button and then press it again. If necessary, repeat this procedure.



Put the drive systems into service one after the other. **Do not** attempt to put several drive systems into service simultaneously. Otherwise the drives will be unable to assign the transmitters precisely.

## 5.3. Programming the DELUXE N RF / CLASSIC N RF / SMARTLINE RF transmitter onto 2nd drive

Sequence for programming a **DELUXE N RF / CLASSIC N RF / SMARTLINE RF** to learn 2nd RF receiver.

### Drive 1:

- Proceed with the **DELUXE N RF / CLASSIC N RF / SMARTLINE RF** as described under section 5.2.

### Drive 1:

- Give the **operating button** on the second **drive 2x short press** (doubleclick) in succession. The **LED under the operating button** comes on after the second pressing, the **drive** now switches to the learning mode for approx. 10s.
- Proceed further with the **DELUXE N RF / CLASSIC N RF / SMARTLINE RF** as described under section 5.2., now you must press the **buttons 3-4 simultaneously**.

# Quick Reference Guide to System

## OKIMAT RF 2,40GHz

### DELUXE N RF / CLASSIC N RF / SMARTLINE RF

---

#### 5.4. Deactivating the DELUXE N RF / CLASSIC N RF / SMARTLINE RF transmitter

If the learning procedure for an RF transmitter has been unsuccessful or the transmitter is taken out of service, you can interrupt communications between the transmitter and the drive as follows:

- Give the **operating button** on the **drive 4x short press** in succession. The LED under the operating button comes on. Now actuate the **operating button 1x**. The LED under the operating button lighting extinguishes and the transmitter is deactivated.

#### 6. Operation

After having been put into operation in accordance with section 5., the drive system is ready for use.

#### 6.1. Basic adjustment functions

By actuating buttons 1 - 6 (see section 4, availability and function depending on the drive system) the drive can be operated.

#### 6.2. Resetting if the hand transmitter fails

If the hand transmitter should fail (for example the batteries are drained) or in the event of a power supply failure, the reset function will allow you to return the application to its home position. To use this function simply press and hold down the reset button on the drive.

#### 6.3. Resetting if the power fails

Power is supplied to the OKIMAT RF 2,40GHz via one or two 9V-block batteries. In order to prevent the block batteries from discharging prematurely, these are **not** connected at the factory. Only in case of failure power supply should the batteries be connected to achieve lowering. Movement of the drive is limited to a one-time reset operation. Afterwards, the block batteries must be replaced in order to ensure lowering for the next reset situation. The drives can be moved to the home position by pressing the operating button.

#### 6.4 Connection of the block batteries (Type: 6LR61)

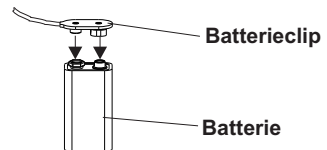
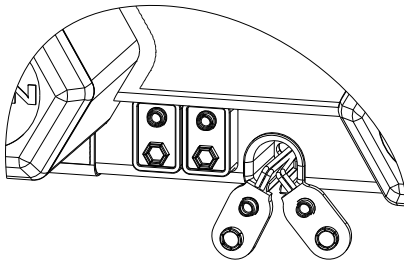

## 7. Table of faults/errors

Should a fault/error occur that is not listed in this table, please contact your supplier.

Problem	Solution
LED in the handset does not light up	<ul style="list-style-type: none"> <li>- Check that batteries are poled correctly.</li> <li>- Change the batteries.</li> <li>- Check the mains connection of the drive, if necessary restore it.</li> <li>- Check whether the transmitter has undergone the learning procedure. If this is the case, then the control system is defective.</li> </ul>
Receiver does not respond	<ul style="list-style-type: none"> <li>- Reduce the distance to the drive system (receiver)</li> <li>- Ensure that no other transmitter is operated simultaneously, e.g. garage door opener, car key etc.</li> <li>- Check whether the transmitter has undergone the learning procedure.</li> <li>- Check the mains power and if necessary, restore it</li> </ul>
Despite programming, no function	<ul style="list-style-type: none"> <li>- Repeat the learning procedure</li> <li>- Contact your dealer</li> </ul>
Several receivers react simultaneously	<ul style="list-style-type: none"> <li>- Relearn the transmitter</li> </ul>