

Quick Reference Guide to System

OKIMAT 8 RF 2,40 GHz / DELUXE N RF

OKIMAT 8 RF 2,40 GHz / CLASSIC N RF



A Phoenix Mecano Company

1. System overview

The system comprises a double drive of the **OKIMAT 8 / OKIMAT 8+1 / OKIMAT 8+2** type with integrated radio receiver enabling trouble-free operation of several drive systems within the radio system's transmission range.

Front view:

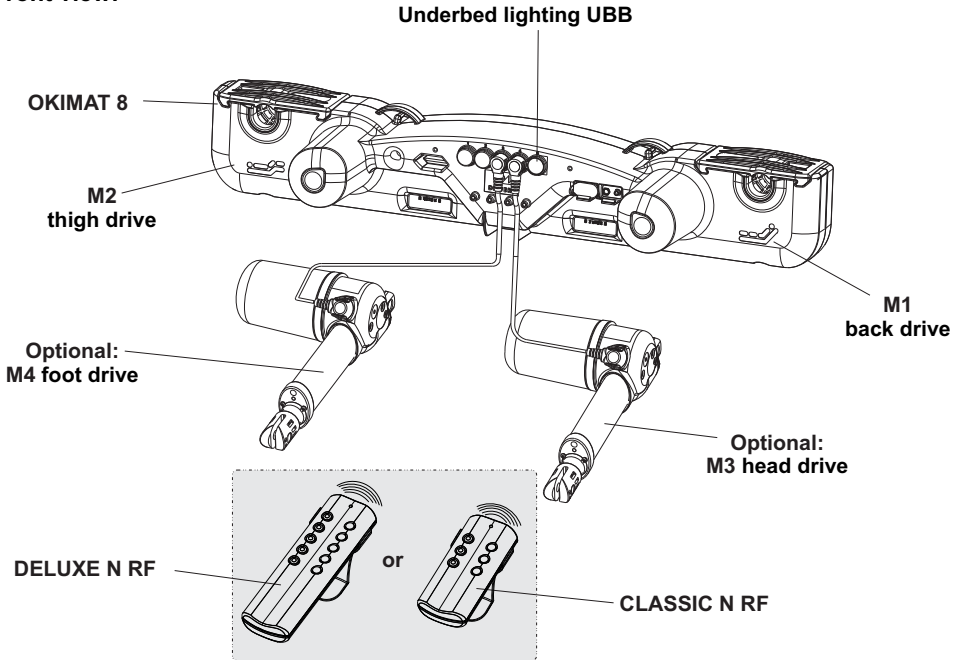

Back view:

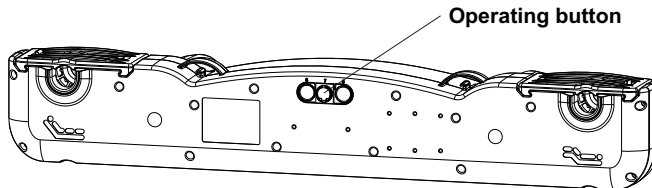

Quick Reference Guide to System

OKIMAT 8 RF 2,40 GHz / DELUXE N RF

OKIMAT 8 RF 2,40 GHz / CLASSIC N RF

2. Button configuration and symbols

The **DELUXE N RF** transmitter is a radio transmitter with a maximum of 8 push-buttons. The **CLASSIC N RF** transmitter is a radio transmitter with a maximum of 6 push-buttons. The number and function of the buttons depends on the equipment and function of the drive system.

Functions LED

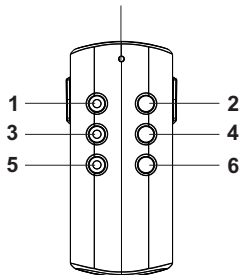

CLASSIC N RF

Symbol	Function
	Head adjustment
	Back adjustment
	Thigh adjustment
	Foot adjustment
	Tilt mattress base of bed
	Adjustment of all drives simultaneously

Functions LED

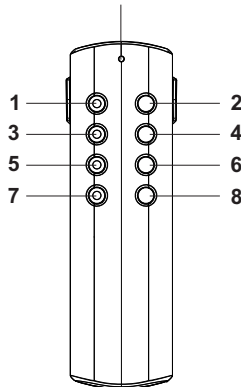

DELUXE N RF

Button	Function
1,3,5	Drives UP
2,4,6	Drives DOWN
1 and 2	Underbed lighting

Button	Function
1,3,5	Drives UP
2,4,6	Drives DOWN
7,8	Underbed lighting

3. Inserting or changing batteries

- Insert a coin into the slot in the top of the **transmitter**. Turn the coin obliquely and carefully press the two halves of the housing apart.
- Change the battery. Only use batteries of the CR 2032 type.
Ensure correct polarity!
- Press the two halves of the housing back together.

CLASSIC N RF

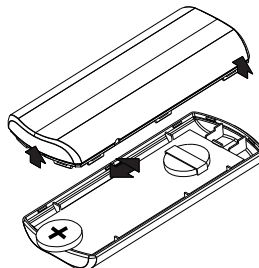
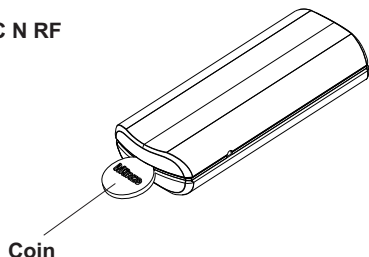

DELUXE N RF

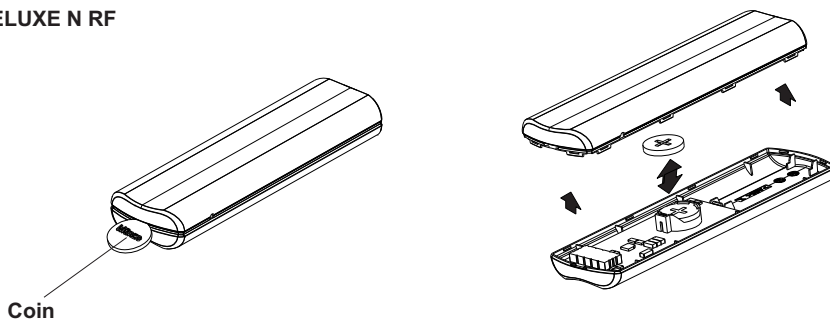

Do not dispose of batteries with the normal household waste!



4. Putting into operation

4.1. Operating button

- Plug the mains plug into the wall socket.
- Wait at least 10s before proceeding with the following steps.
- In order to carry out these steps, it will be necessary to actuate the **operating button**. By carefully pressing the button, various drive functions can be called up.

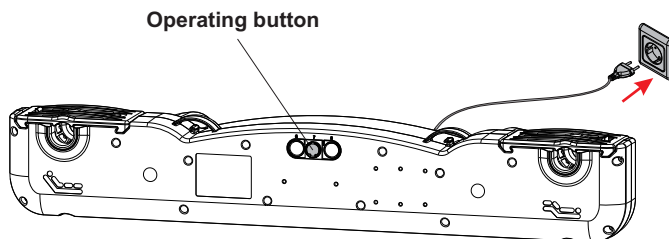

Quick Reference Guide to System

OKIMAT 8 RF 2,40 GHz / DELUXE N RF

OKIMAT 8 RF 2,40 GHz / CLASSIC N RF

4.2. Programming the DELUXE N RF / CLASSIC N RF transmitter

In order to put the handset into operation, radio communications with the drive must first be established. To do this, proceed as follows:

- Give the **operating button** on the **drive 2x short press** in succession. The underberbed lighting comes on, the **RF-receiver** now switches to the learning mode for approx. 10s.
- Press **buttons 1-2 simultaneously and keep them pressed** until the underberbed lighting extinguishes and the function LED glows constantly (programmable process approx. 10s)). The learning mode of the **DELUXE N RF** or **CLASSIC N RF** transmitter is completed.
- The **DELUXE N RF** or **CLASSIC N RF** transmitter is ready for operation.

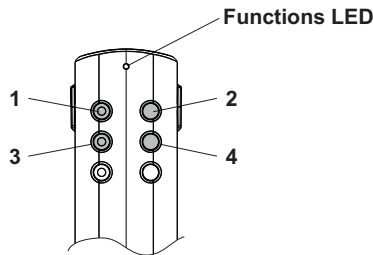

If the drive does not start up when the button is pressed, briefly release the button and then press it again. If necessary, repeat this procedure.



Put the drive systems into service one after the other. **Do not** attempt to put several drive systems into service simultaneously. otherwise the drives will be unable to assign the **DELUXE N RF** or **CLASSIC N RF** transmitters precisely.

4.3. Programming the DELUXE N RF or CLASSIC N RF transmitter onto 2nd drive

Sequence for programming a **DELUXE N RF** or **CLASSIC N RF** to learn 2nd RF receiver.

Drive 1:

- Proceed with the **DELUXE N RF** or **CLASSIC N RF** as described under section 4.2.

Drive 2:

- Give the **operating button** on the second **drive 2x short press** in succession. The underberbed lighting comes on, the **RF-receiver** now switches to the learning mode for approx. 10s.
- Proceed further with the **DELUXE N RF** or **CLASSIC N RF** as described under section 4.2., now you must press the **buttons 3-4 simultaneously**.

4.4. Deactivating the DELUXE N RF / CLASSIC N RF transmitter

If the learning procedure for an RF transmitter has been unsuccessful or the transmitter is taken out of service, you can interrupt communications between the transmitter and the drive as follows:

- Give the **operating button** on the **drive 4x short press** in succession. The underbed lighting comes on. Now actuate the **operating button 1x**. The underbed lighting extinguishes and the **DELUXE N RF** or **CLASSIC N RF** transmitter is deactivated.

4.5. Attaching or removing the fastening clip

- To attach, press the fastening clip **(1)** into the two notches **(3)** on the underside **(2)** of the **DELUXE N RF** or **CLASSIC N RF** transmitter. The fastening clip snaps into place.
- To remove, prize the fastening clip **carefully** out of the two notches **(3)**.

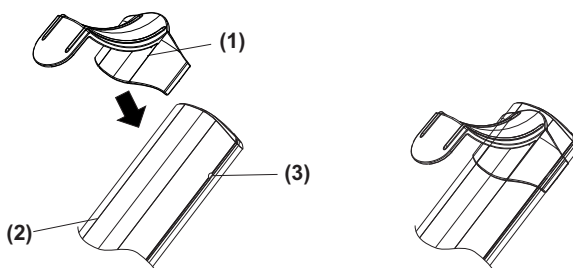

Quick Reference Guide to System

OKIMAT 8 RF 2,40 GHz / DELUXE N RF

OKIMAT 8 RF 2,40 GHz / CLASSIC N RF



5. Operation

After having been put into operation in accordance with section 4., the drive system is ready for use.

5.1. Basic adjustment functions

By actuating buttons 1 - 6 (see section 2, availability and function depending on the drive system) the drive can be operated.

5.2. Operating the underbed lighting (UBB) DELUXE N RF

- Press **button 7 or 8** (symbol , see section 2), the LED of the UBB lights up.
- Press **button 7 or 8** (symbol ) again, the UBB extinguishes.

5.3. Operating the underbed lighting (UBB) CLASSIC N RF

- Press **button 1 - 2 simultaneously** (see section 2), the LED of the UBB lights up.
- Press **button 1 - 2 simultaneously** again, the UBB extinguishes.

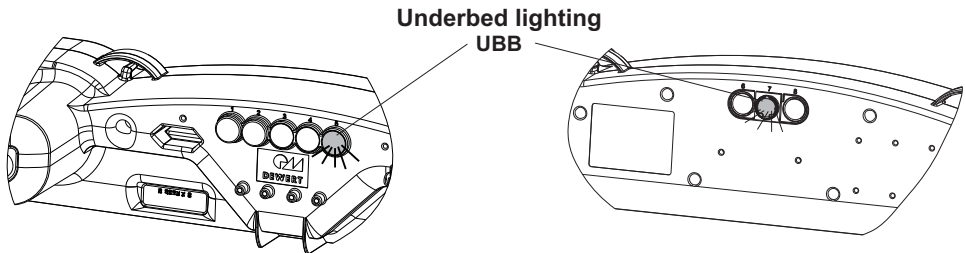

5.4 Resetting

The resetting function allows the mattress base of the bed to be moved to the sleeping position in the event of a power or hand transmitter failure (e.g. batteries depleted).

5.5. Resetting in the event of a power failure

Power is supplied to the OKIMAT 8 via two 9V-block batteries. In order to prevent the block batteries from discharging prematurely, these are **not** connected at the factory. Only at the time of the emergency should the batteries be connected to achieve resetting. Movement of the drive is limited to a one-time emergency manual operation. Afterwards, the block batteries must be replaced in order to ensure resetting for the next emergency situation. The drives can be moved to the home position by pressing the operating button.

5.6 Emergency lowering on failure of the DELUXE N RF or CLASSIC N RF transmitter

The drives can be moved to the home position by pressing the operating button.

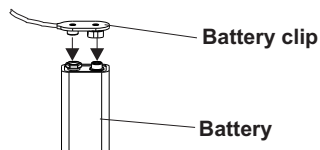
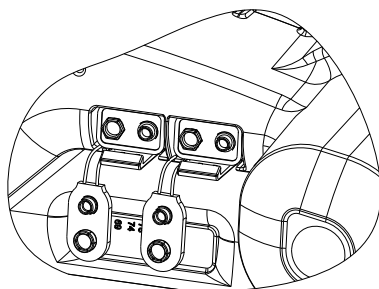

6. Table of faults/errors

Should a fault/error occur that is not listed in this table, please contact your supplier.

Problem	Solution
LED in the DELUXE N RF or CLASSIC N RF does not light up	<ul style="list-style-type: none"> - Check that batteries are poled correctly. - Change the batteries. - Check the mains connection of the drive, if necessary restore it. - Check whether the transmitter has undergone the learning procedure. If this is the case, then the control system is defective.
Receiver does not respond	<ul style="list-style-type: none"> - Reduce the distance to the drive system (receiver) - Ensure that no other transmitter is operated simultaneously, e.g. garage door opener, car key etc. - Check whether the transmitter has undergone the learning procedure. - Check the mains power and if necessary, restore it
Despite programming, no function	<ul style="list-style-type: none"> - Repeat the learning procedure - Contact your dealer
Several receivers react simultaneously	<ul style="list-style-type: none"> - Relearn the transmitter